



DECLARATION OF PERFORMANCE



DoP: 0174

for fischer Superbond (Bonded anchor for use in concrete) – EN

1. Unique identification code of the product-type: **DoP: 0174**
2. Intended use/es: **Post-installed fastening in cracked or uncracked concrete, see appendix, especially Annexes B 1 to B 15**
3. Manufacturer: **fischerwerke GmbH & Co. KG, Otto-Hahn-Straße 15, 79211 Denzlingen, Germany**
4. Authorised representative: --
5. System/s of AVCP: **1**
6. European Assessment Document: **EAD 330499-01-0601**

European Technical Assessment: **ETA-12/0258; 2019-07-22**

Technical Assessment Body: **DIBt**

Notified body/ies: **1343 – MPA Darmstadt**

7. Declared performance/s:

Mechanical resistance and stability (BWR 1)

- **Characteristic resistance to tension load (static and quasi-static loading):**
See appendix, especially Annexes B 4 – B 8, C 1 – C 10
- **Characteristic resistance to shear load (static and quasi-static loading):** See appendix, especially Annexes C 1 – C 4
- **Displacements (static and quasi-static loading):** See appendix, especially Annexes C 11, C 12
- **Durability:** See appendix, especially Annex A 7, B 3
- **Characteristic resistance and displacements for seismic performance categories C1 and C2:**
See appendix, especially Annexes A 7, C 13 – C 16
 - **Factor for annular gap (α_{gap}) = 1,0 (filled gap) respectively 0,5 (non-filled gap)**
 - **Displacements ($\delta_{N,eq}$, $\delta_{V,eq}$) for C1: NPD**

Hygiene, health and the environment (BWR 3)

- **Content, emission and/or release of dangerous substances:** See appendix, especially page 3 / NPD

8. Appropriate Technical Documentation and/or Specific Technical Documentation: ---

The performance of the product identified above is in conformity with the set of declared performance/s. This declaration of performance is issued, in accordance with Regulation (EU) No 305/2011, under the sole responsibility of the manufacturer identified above.

Signed for and on behalf of the manufacturer by:

Thilo Pregartner, Dr.-Ing.

Wolfgang Hengesbach, Dipl.-Ing., Dipl.-Wirtsch.-Ing.

Tumlingen, 2019-11-15

- This DoP has been prepared in different languages. In case there is a dispute on the interpretation the english version shall always prevail.
- The Appendix includes voluntary and complementary information in English language exceeding the (language-neutrally specified) legal requirements.

Specific Part

1 Technical description of the product

The injection system fischer Superbond is a bonded anchor for use in concrete consisting of a cartridge with injection mortar fischer FIS SB or a resin capsule fischer RSB and a steel element according to Annex A 5.

The steel element is placed into a drilled hole filled with injection mortar and is anchored via the bond between metal part, injection mortar and concrete.

The resin capsule is placed into the hole and the steel element is driven by machine with simultaneous hammering and turning. The anchor rod is anchored via the bond between steel element, chemical mortar and concrete.

The product description is given in Annex A.

2 Specification of the intended use in accordance with the applicable European Assessment Document

The performances given in Section 3 are only valid if the anchor is used in compliance with the specifications and conditions given in Annex B.

The verifications and assessment methods on which this European Technical Assessment is based lead to the assumption of a working life of the anchor of at least 50 years. The indications given on the working life cannot be interpreted as a guarantee given by the producer, but are to be regarded only as a means for choosing the right products in relation to the expected economically reasonable working life of the works.

3 Performance of the product and references to the methods used for its assessment

3.1 Mechanical resistance and stability (BWR 1)

Essential characteristic	Performance
Characteristic resistance for static and quasi-static tension load	See Annex C 1 to C 10
Characteristic resistance for static and quasi-static shear load	See Annex C 1 to C 4
Displacements for static and quasi-static loads	See Annex C 11 to C 12
Characteristic resistance for seismic performance categories C1 and C2	See Annex C 13 to C 16
Durability	See Annex B 3

3.2 Hygiene, health and the environment (BWR 3)

Essential characteristic	Performance
Content, emission and/or release of dangerous substances	No performance assessed

4 Assessment and verification of constancy of performance (AVCP) system applied, with reference to its legal base

In accordance with European Assessment Document EAD 330499-01-0601 the applicable European legal act is: [96/582/EC].

The system to be applied is: 1

Installation conditions part 1

anchor rod or fischer anchor rod RG M with fischer injection system FIS SB

Pre-positioned installation

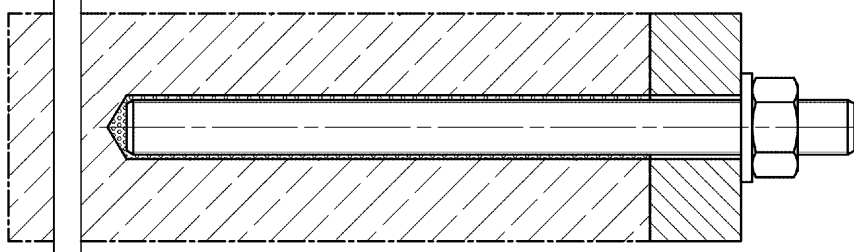

Push through installation (annular gap filled with mortar)

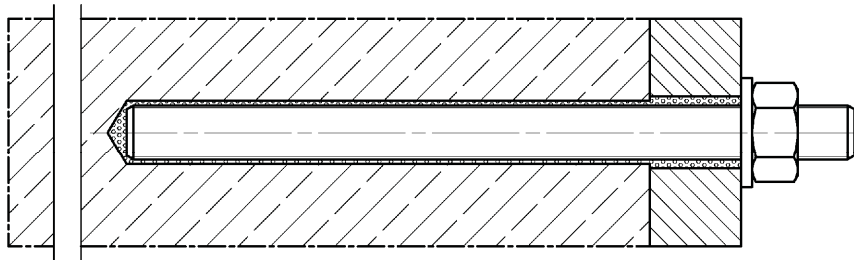

Pre-positioned or push through installation with subsequently injected filling disk
(annular gap filled with mortar)

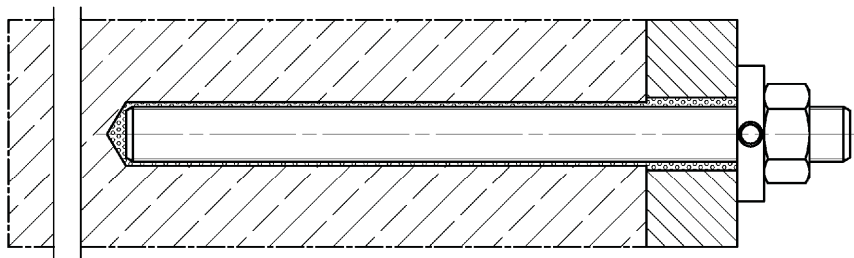

Figures not to scale

fischer Superbond

Product description
Installation conditions part 1

Annex A 1

Installation conditions part 2

Reinforcing bar with fischer injection system FIS SB

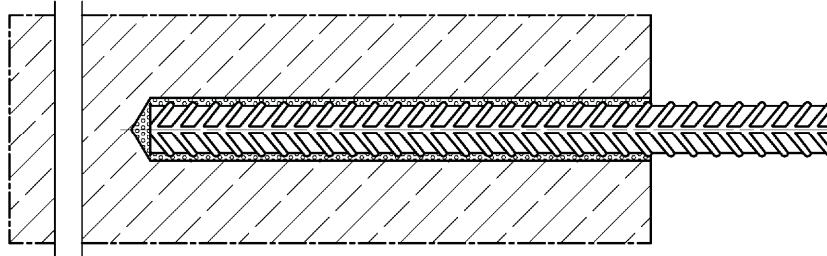

fischer rebar anchor FRA with fischer injection system FIS SB

Pre-positioned installation

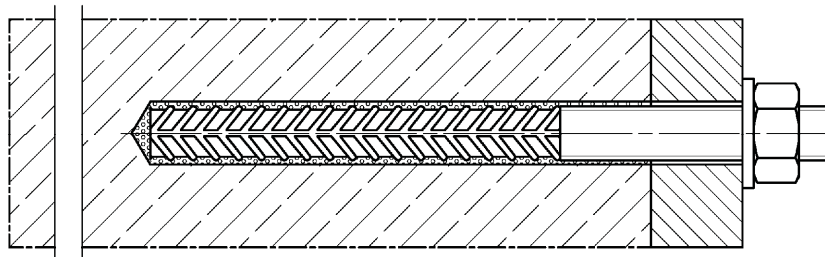

Push through installation (annular gap filled with mortar)

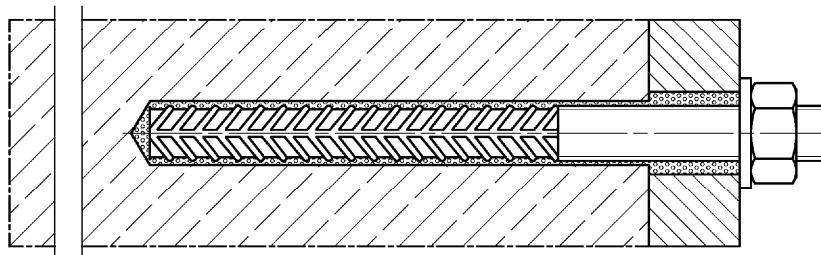

Figures not to scale

fischer Superbond

Product description
Installation conditions part 2

Annex A 2

Installation conditions part 3

fischer internal threaded anchor RG MI with fischer resin capsule system RSB or fischer injection system FIS SB

Pre-positioned installation

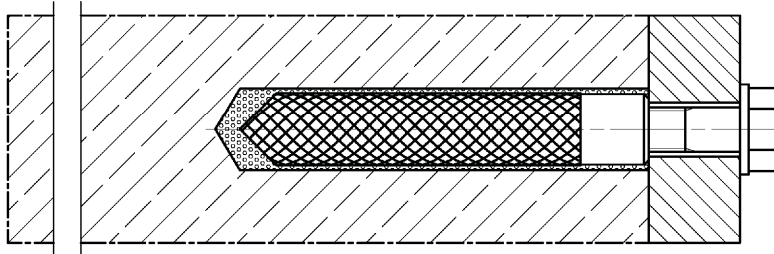

Pre-positioned installation with subsequently injected filling disk (annular gap filled with mortar)

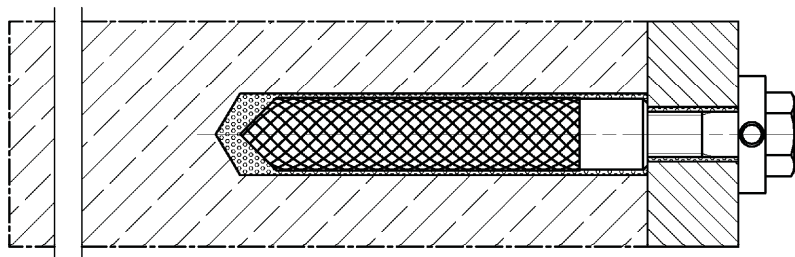

fischer anchor rod RG M with fischer resin capsule system RSB

Pre-positioned installation

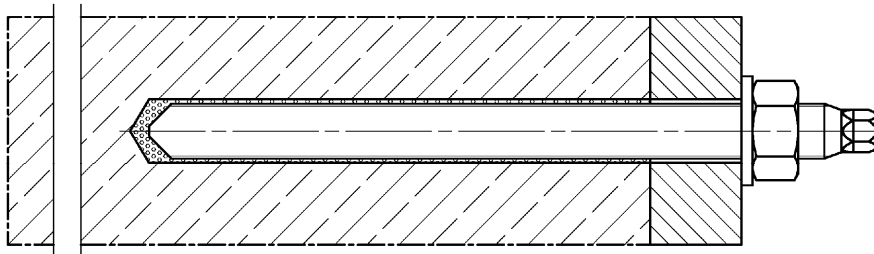

Pre-positioned installation with subsequently injected filling disk (annular gap filled with mortar)

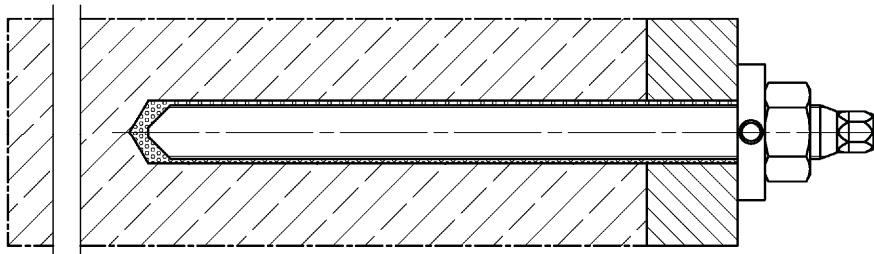

Figures not to scale

fischer Superbond

Product description
Installation conditions part 3

Annex A 3

Overview system components Part 1

Mortar cartridge (shuttle cartridge) with sealing cap; Sizes: 390 ml, 585 ml, 1100 ml, 1500 ml

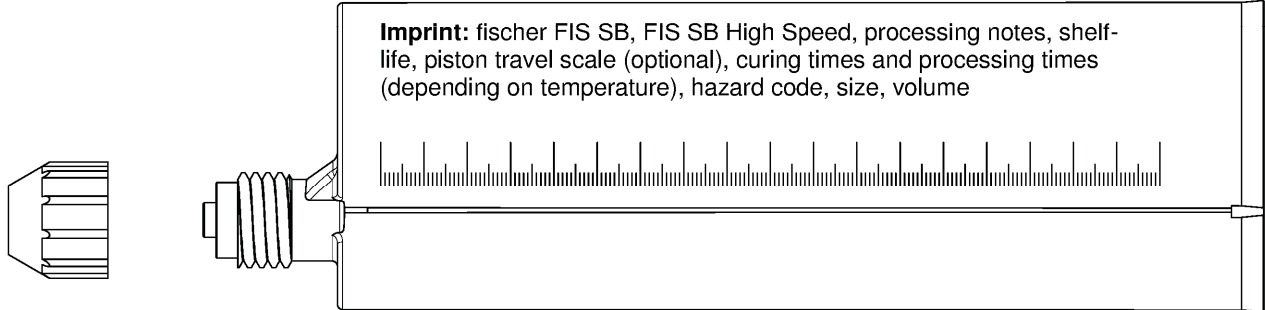

Resin capsule

Sizes: 8, 10 mini, 10, 12 mini, 12, 16 mini, 16, 16 E, 20, 20 E / 24, 30



Static mixer FIS MR Plus or UMR

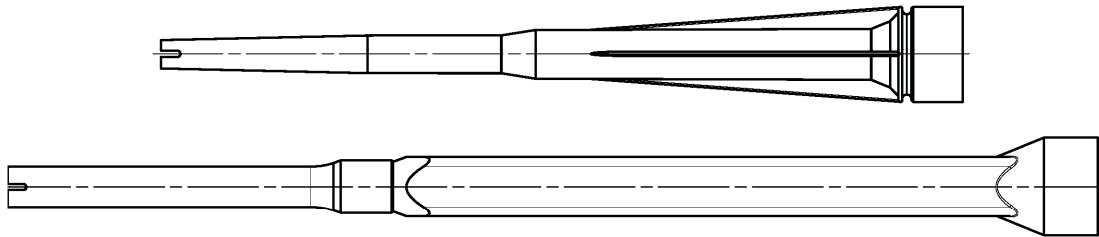

Injection adapter / extension tube for static mixer

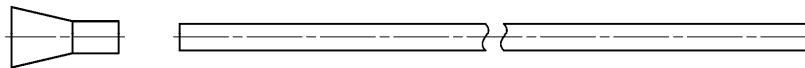

Figures not to scale

fischer Superbond

System description

Overview system components part 1;
cartridges / capsule / static mixer / injection adapter

Annex A 4

Overview system components Part 2

anchor rod

Sizes: M8, M10, M12, M16, M20, M24, M27, M30

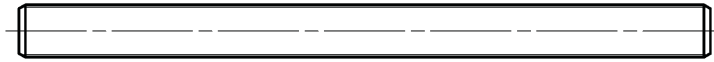

fischer anchor rod RG M

Sizes: M8, M10, M12, M16, M20, M24, M30

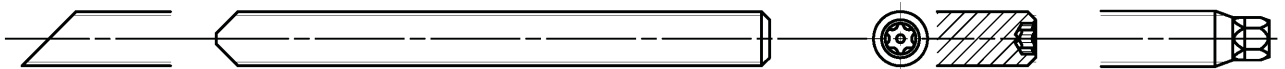

fischer internal threaded anchor RG MI

Size: M8, M10, M12, M16, M20

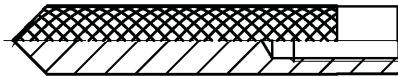

Screw / threaded rod / washer / hexagon nut

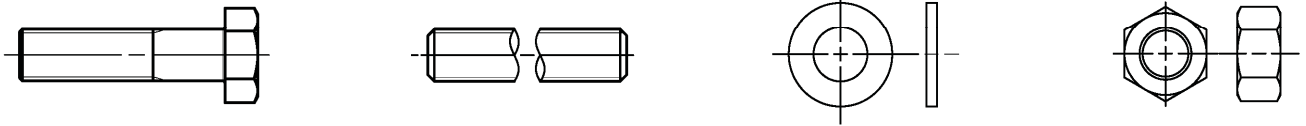

fischer filling disc with injection adapter

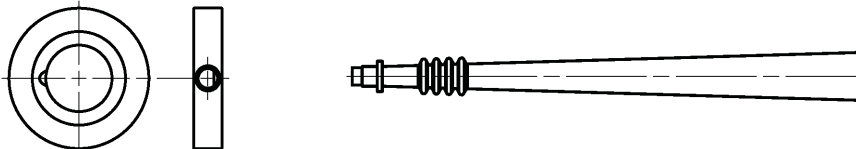

Reinforcing bar

Nominal diameters: $\phi 8$, $\phi 10$, $\phi 12$, $\phi 14$, $\phi 16$, $\phi 20$, $\phi 25$, $\phi 28$, $\phi 32$



fischer rebar anchor FRA

Sizes: M12, M16, M20, M24



Figures not to scale

fischer Superbond

System description
Overview system components part 2;
steel components

Annex A 5

Overview system components Part 3

Cleaning brush BS / BSB



Blow-out pump ABG or ABP with cleaning nozzle









Figures not to scale





fischer Superbond

System description
 Overview system components part 3;
 cleaning brush / blow-out pump / injection adapter

Annex A 6

Table A7.1: Materials				
Part	Designation	Material		
1	Injection cartridge	Mortar, hardener, filler		
	Steel grade	Steel, zinc plated	Stainless steel A4 ¹⁾	High corrosion resistant steel C ²⁾
2	Anchor rod	Property class 5.8 or 8.8; EN ISO 898-1:2013 zinc plated $\geq 5 \mu\text{m}$, EN ISO 4042:1999 A2K or hot-dip galvanized $\geq 40 \mu\text{m}$ EN ISO 10684:2004 $f_{uk} \leq 1000 \text{ N/mm}^2$ $A_5 > 12\%$ fracture elongation	Property class 50, 70 or 80 EN ISO 3506-1:2009 1.4401; 1.4404; 1.4578; 1.4571; 1.4439; 1.4362; 1.4062, 1.4662, 1.4462; EN 10088-1:2014 ¹⁾ $f_{uk} \leq 1000 \text{ N/mm}^2$ $A_5 > 12\%$ fracture elongation	Property class 50 or 80 EN ISO 3506-1:2009 or property class 70 with $f_{yk} = 560 \text{ N/mm}^2$ 1.4565; 1.4529; EN 10088-1:2014 $f_{uk} \leq 1000 \text{ N/mm}^2$ $A_5 > 12\%$ fracture elongation
Fracture elongation $A_5 > 8 \%$, for applications without requirements for seismic performance category C2				
3	Washer ISO 7089:2000	zinc plated $\geq 5 \mu\text{m}$, EN ISO 4042:1999 A2K or hot-dip galvanized $\geq 40 \mu\text{m}$ EN ISO 10684:2004	1.4401; 1.4404; 1.4578; 1.4571; 1.4439; 1.4362; EN 10088-1:2014	1.4565; 1.4529; EN 10088-1:2014
4	Hexagon nut	Property class 5 or 8; EN ISO 898-2:2012 zinc plated $\geq 5 \mu\text{m}$, ISO 4042:1999 A2K or hot-dip galvanized $\geq 40 \mu\text{m}$ EN ISO 10684:2004	Property class 50, 70 or 80 EN ISO 3506-1:2009 1.4401; 1.4404; 1.4578; 1.4571; 1.4439; 1.4362; EN 10088-1:2014	Property class 50, 70 or 80 EN ISO 3506-1:2009 1.4565; 1.4529 EN 10088-1:2014
5	fischer internal threaded anchor RG MI	Property class 5.8 ISO 898-1:2013 zinc plated $\geq 5 \mu\text{m}$, ISO 4042:1999 A2K	Property class 70 EN ISO 3506-1:2009 1.4401; 1.4404; 1.4578; 1.4571; 1.4439; 1.4362; EN 10088-1:2014	Property class 70 EN ISO 3506-1:2009 1.4565; 1.4529; EN 10088-1:2014
6	Commercial standard screw or anchor / threaded rod for fischer internal threaded anchor RG MI	Property class 5.8 or 8.8; EN ISO 898-1:2013 zinc plated $\geq 5 \mu\text{m}$, ISO 4042:1999 A2K $A_5 > 8 \%$ fracture elongation	Property class 70 EN ISO 3506-1:2009 1.4401; 1.4404; 1.4578; 1.4571; 1.4439; 1.4362; EN 10088-1:2014 ¹⁾ $A_5 > 8 \%$ fracture elongation	Property class 70 EN ISO 3506-1:2009 1.4565; 1.4529; EN 10088-1:2014 $A_5 > 8 \%$ fracture elongation
7	fischer filling disk FFD similar to DIN 6319-G	zinc plated $\geq 5 \mu\text{m}$, EN ISO 4042:1999 A2K or hot-dip galvanized $\geq 40 \mu\text{m}$ EN ISO 10684:2004	1.4401; 1.4404; 1.4578; 1.4571; 1.4439; 1.4362; EN 10088-1:2014	1.4565; 1.4529; EN 10088-1:2014
8	Reinforcing bar EN 1992-1-1:2004 and AC:2010, Annex C	Bars and de-coiled rods, class B or C with f_{yk} and k according to NDP or NCL of EN 1992-1-1:2004+AC:2010 $f_{uk} = f_{tk} = k \cdot f_{yk}$		
9	fischer rebar anchor FRA	Rebar part: Bars and de-coiled rods class B or C with f_{yk} and k according to NDP or NCL of EN 1992-1-1:2004+AC:2010 $f_{uk} = f_{tk} = k \cdot f_{yk}$	Threaded part: Property class 70 or 80 EN ISO 3506-1:2009 1.4401, 1.4404, 1.4571, 1.4578, 1.4439, 1.4362, 1.4062 EN 10088-1:2014 ¹⁾ 1.4565; 1.4529 EN 10088-1:2014 ²⁾	
¹⁾ acc. to EN 10088-1:2014 Corrosion resistance class CRC III acc. to EN 1993-1-4:2015 ²⁾ acc. to EN 10088-1:2014 Corrosion resistance class CRC V acc. to EN 1993-1-4:2015				
fischer Superbond				Annex A 7
Product description Materials				

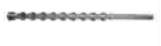
Specifications of intended use (part 1)									
Table B1.1: Overview use and performance categories, injection mortar system FIS SB									
Anchorages subject to		FIS SB with ...							
		anchor rod 		fischer internal threaded anchor RG MI 		Reinforcing bar 		fischer rebar anchor FRA 	
Hammer drilling with standard drill bit 		all sizes							
Hammer drilling with hollow drill bit (fischer "FHD", Heller "Duster Expert"; Bosch „Speed Clean“; Hilti "TE-CD, TE-YD") 		Nominal drill bit diameter (d_0) 12 mm to 35 mm							
Diamond drilling 		not permitted							
Static and quasi static load, in		uncracked concrete		Tables: C1.1 C4.1		Tables: C2.1 C4.1		Tables: C3.1 C4.1	
		cracked concrete		C5.1 C11.1		C7.1 C11.2		C9.1 C12.1	
Seismic performance category (only hammer drilling with standard / hollow drill bits)		C1		Tables: C13.1 C14.2 C15.1		---		Tables: C14.1 C14.2 C15.2	
		C2		M12 M16 M20 M24		Tables: C13.1 C14.2 C16.1		---	
Use category		11 dry or wet concrete		all sizes					
		12 water filled hole		not permitted					
Installation direction		D3 (downward and horizontal and upwards (overhead) installation)							
Installation method		pre-positioned or push through installation							
Installation temperature		FIS SB: $T_{i,min} = -15\text{ °C}$ to $T_{i,max} = +40\text{ °C}$ FIS SB High Speed: $T_{i,min} = -20\text{ °C}$ to $T_{i,max} = +40\text{ °C}$							
In-service temperature		Temperature range I		-40 °C to +40 °C		$T_{st} = +40\text{ °C}$ / $T_{lt} = +24\text{ °C}$			
		Temperature range II		-40 °C to +80 °C		$T_{st} = +80\text{ °C}$ / $T_{lt} = +50\text{ °C}$			
		Temperature range III		-40 °C to +120 °C		$T_{st} = +120\text{ °C}$ / $T_{lt} = +72\text{ °C}$			
		Temperature range IV		-40 °C to +150 °C		$T_{st} = +150\text{ °C}$ / $T_{lt} = +90\text{ °C}$			
fischer Superbond								Annex B 1	
Intended use Specifications (part 1), fischer injection mortar system FIS SB									

Specifications of intended use (part 2)					
Table B2.1: Overview use and performance categories, resin capsule system RSB					
Anchorages subject to		RSB with ...			
		fischer anchor rod RG M 	fischer internal threaded anchor RG MI 		
Hammer drilling with standard drill bit 	all sizes				
Hammer drilling with hollow drill bit (fischer "FHD", Heller "Duster Expert"; Bosch „Speed Clean“; Hilti "TE-CD, TE-YD") 	Nominal drill bit diameter (d_0) 12 mm to 35 mm			all sizes	
Diamond drilling 	all sizes ¹⁾				
Static and quasi static load, in	uncracked concrete	all sizes	Tables: C1.1 C4.1 C6.1 C11.1	all sizes	Tables: C2.1 C4.1 C8.1 C11.2
	cracked concrete	all sizes ¹⁾		all sizes ¹⁾	
Seismic performance category (only hammer drilling with standard / hollow drill bits)	C1	all sizes	Tables: C13.1 C14.2 C15.1	---	
	C2	---			
Use category	I1 dry or wet concrete	all sizes			
	I2 water filled hole	all sizes			
Installation direction		D3 (downward and horizontal and upwards (overhead) installation)			
Installation method		only pre-positioned installation			
Installation temperature		$T_{i,min} = -30\text{ °C}$ to $T_{i,max} = +40\text{ °C}$			
In-service temperature	Temperature range I	-40 °C to +40 °C	$T_{st} = +40\text{ °C}$ / $T_{lt} = +24\text{ °C}$		
	Temperature range II	-40 °C to +80 °C	$T_{st} = +80\text{ °C}$ / $T_{lt} = +50\text{ °C}$		
	Temperature range III	-40 °C to +120 °C	$T_{st} = +120\text{ °C}$ / $T_{lt} = +72\text{ °C}$		
	Temperature range IV	-40 °C to +150 °C	$T_{st} = +150\text{ °C}$ / $T_{lt} = +90\text{ °C}$		
¹⁾ For diamond drilling in cracked concrete only nominal drill bit diameters (d_0) ≥ 18 mm are permitted					
fischer Superbond					Annex B 2
Intended use Specifications (part 2), fischer resin capsule system RSB					

Specifications of intended use (part 3)

Base materials:

- Compacted reinforced or unreinforced normal weight concrete without fibres of strength classes C20/25 to C50/60 according to EN 206:2013+A1:2016

Use conditions (Environmental conditions):

- Structures subject to dry internal conditions (zinc coated steel, stainless steel or high corrosion resistant steel).
- For all other conditions according to EN1993-1-4:2015 corresponding to corrosion resistance classes to Annex A 7 table 7.1.

Design:

- Anchorages have to be designed by a responsible engineer with experience of concrete anchor design.
- Verifiable calculation notes and drawings are to be prepared taking account of the loads to be anchored. The position of the anchor is indicated on the design drawings (e. g. position of the anchor relative to reinforcement or to supports, etc.).
- Anchorages are designed in accordance with:
EN 1992-4:2018 and EOTA Technical Report TR 055.
Anchorages shall be positioned outside of critical regions (e.g. plastic hinges) of the concrete structure. Fastening in stand-off installation or with a grout layer under seismic action are not covered in this European Technical Assessment (ETA).

Installation:

- Anchor installation is to be carried out by appropriately qualified personnel and under the supervision of the person responsible for technical matters of the site
- In case of aborted hole: The hole shall be filled with mortar
- Anchorage depth should be marked and adhered to on installation
- Overhead installation is allowed

fischer Superbond

Intended use
Specifications (part 3)

Annex B 3

Table B4.1: Installation parameters for **anchor rods** in combination with **injection mortar system FIS SB**

Anchor rods		Thread	M8	M10	M12	M16	M20	M24	M27	M30
Width across flats	SW	[mm]	13	17	19	24	30	36	41	46
Nominal drill hole diameter	d_0		10	12	14	18	24	28	30	35
Drill hole depth	h_0		$h_0 = h_{ef}$							
Effective embedment depth	$h_{ef, min}$		60	60	70	80	90	96	108	120
	$h_{ef, max}$		160	200	240	320	400	480	540	600
Minimum spacing and minimum edge distance	S_{min} =		40	45	55	65	85	105	120	140
	C_{min}									
Diameter of the clearance hole of the fixture	pre-positioned installation d_f		9	12	14	18	22	26	30	33
	push through installation d_f		11	14	16	20	26	30	33	40
Min. thickness of concrete member	h_{min}		$h_{ef} + 30$ (≥ 100)			$h_{ef} + 2d_0$				
Maximum torque moment for attachment of the fixture	$\max T_{fix}$	[Nm]	10	20	40	60	120	150	200	300

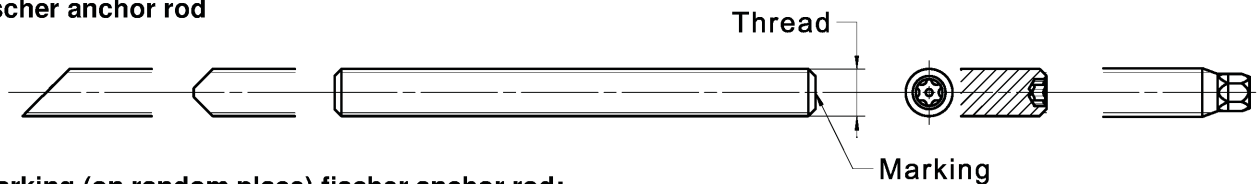
fischer anchor rod**Marking (on random place) fischer anchor rod:**

Property class 8.8, stainless steel, property class 80 and high corrosion resistant steel, property class 80: •
 Stainless steel A4, property class 50 and high corrosion resistant steel, property class 50: ••
 Alternatively: Colour coding according to DIN 976-1

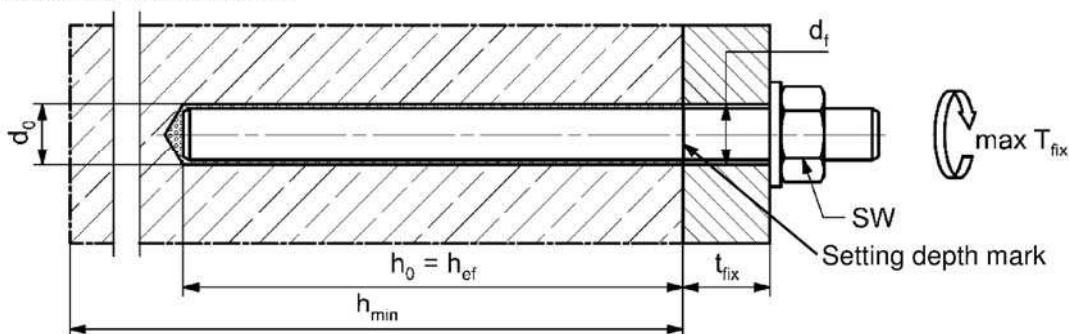
Installation conditions:**Commercial standard threaded rods, washers and hexagon nuts may also be used if the following requirements are fulfilled:**

- Materials, dimensions and mechanical properties according to Annex A 7, Table A7.1
- Inspection certificate 3.1 according to EN 10204:2004, the documents have to be stored
- Setting depth is marked

Figures not to scale

fischer Superbond

Intended use

Installation parameters for anchor rods in combination with injection mortar system FIS SB

Annex B 4

Table B5.1: Installation parameters for **fischer anchor rods RG M** in combination with **resin capsule system RSB**

Anchor rod RG M		Thread	M8	M10	M12	M16	M20	M24	M30	
Width across flats	SW	[mm]	13	17	19	24	30	36	46	
Nominal drill hole diameter	d_0		10	12	14	18	25	28	35	
Drill hole depth	h_0		$h_0 = h_{ef}$							
Effective embedment depth	$h_{ef,1}$		---	75	75	95	---	---	---	
	$h_{ef,2}$		80	90	110	125	170	210	280	
	$h_{ef,3}$		---	150	150	190	210	---	---	
Minimum spacing and minimum edge distance	$s_{min} = c_{min}$		40	45	55	65	85	105	140	
Diameter of the pre-clearance hole of the fixture	d_f		9	12	14	18	22	26	33	
Min. thickness of concrete member	h_{min}		$h_{ef} + 30$ (≥ 100)			$h_{ef} + 2d_0$				
Maximum torque moment for attachment of the fixture	$max T_{fix}$		[Nm]	10	20	40	60	120	150	300

fischer anchor rod RG M

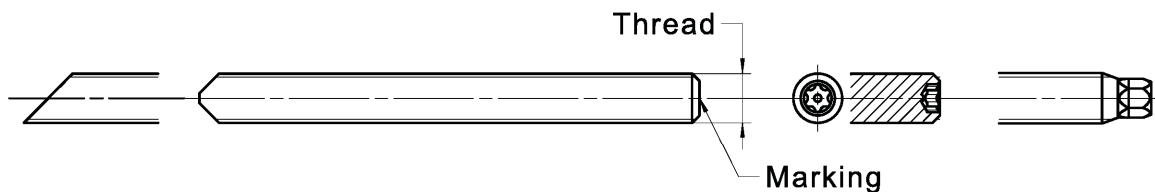

Marking (on random place) fischer anchor rod RG M:

Property class 8.8, stainless steel, property class 80 and high corrosion resistant steel, property class 80: •
 Stainless steel A4, property class 50 and high corrosion resistant steel, property class 50: ••
 Alternatively: Colour coding according to DIN 976-1

Installation conditions:

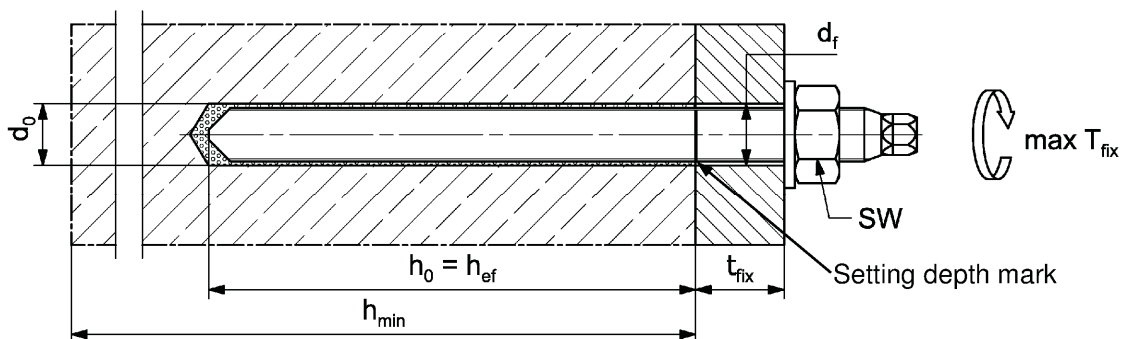

Figures not to scale

fischer Superbond

Intended use

Installation parameters for fischer anchor rods RG M in combination with resin capsule system RSB

Annex B 5

Table B6.1: Installation parameters for **fischer internal threaded anchors RG MI**

Internal threaded anchor RG MI		Thread	M8	M10	M12	M16	M20
Sleeve diameter	$d = d_H$	[mm]	12	16	18	22	28
Nominal drill hole diameter	d_0		14	18	20	24	32
Drill hole depth	h_0		$h_0 = h_{ef} = L_H$				
Effective embedment depth ($h_{ef} = L_H$)	h_{ef}		90	90	125	160	200
Minimum spacing and minimum edge distance	s_{min} = c_{min}		55	65	75	95	125
Diameter of clearance hole in the fixture	d_f		9	12	14	18	22
Minimum thickness of concrete member	h_{min}		120	125	165	205	260
Maximum screw-in depth	$l_{E,max}$		18	23	26	35	45
Minimum screw-in depth	$l_{E,min}$		8	10	12	16	20
Maximum torque moment for attachment of the fixture	$\max T_{fix}$	[Nm]	10	20	40	80	120

fischer internal threaded anchor RG MI

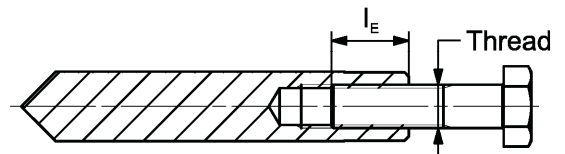
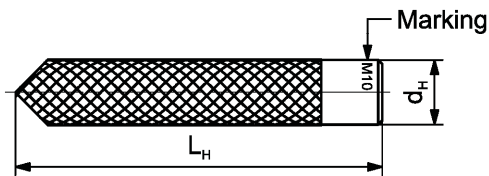

Marking: Anchor size e. g.: **M10**
 Stainless steel → additional **A4**; e.g.: **M10 A4**
 High corrosion resistant steel → additional **C**; e.g.: **M10 C**

Retaining bolt or threaded rods (including nut and washer) must comply with the appropriate material and strength class of Annex A 7, Table A7.1

Installation conditions:

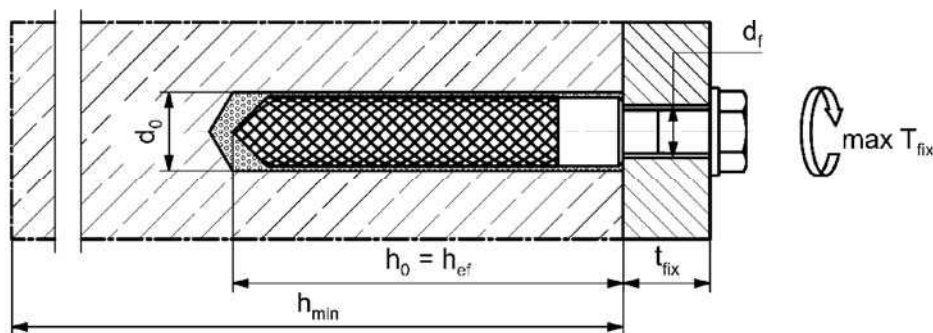

Figures not to scale

fischer Superbond

Intended use
 Installation parameters for fischer internal threaded anchors RG MI

Annex B 6

Table B7.1: Installation parameters for **reinforcing bars**

Nominal diameter of the bar		ϕ	8 ¹⁾	10 ¹⁾	12 ¹⁾	14	16	20	25	28	32			
Nominal drill hole diameter	d_0	[mm]	10	12	12	14	14	16	18	20	25	30	35	40
Drill hole depth	h_0		$h_0 = h_{ef}$											
Effective embedment depth	$h_{ef,min}$		60	60	70	75	80	90	100	112	128			
	$h_{ef,max}$		160	200	240	280	320	400	500	560	640			
Minimum spacing and minimum edge distance	s_{min}		40	45	55	60	65	85	110	130	160			
	c_{min}													
Minimum thickness of concrete member	h_{min}	$h_{ef} + 30$ (≥ 100)				$h_{ef} + 2d_0$								

1) Both drill hole diameters can be used

Reinforcing bar



- The minimum value of related rib area $f_{R,min}$ must fulfil the requirements of EN 1992-1-1:2004+AC:2010
- The rib height must be within the range: $0,05 \cdot \phi \leq h_{rib} \leq 0,07 \cdot \phi$
(ϕ = Nominal diameter of the bar , h_{rib} = rib height)

Installation conditions:

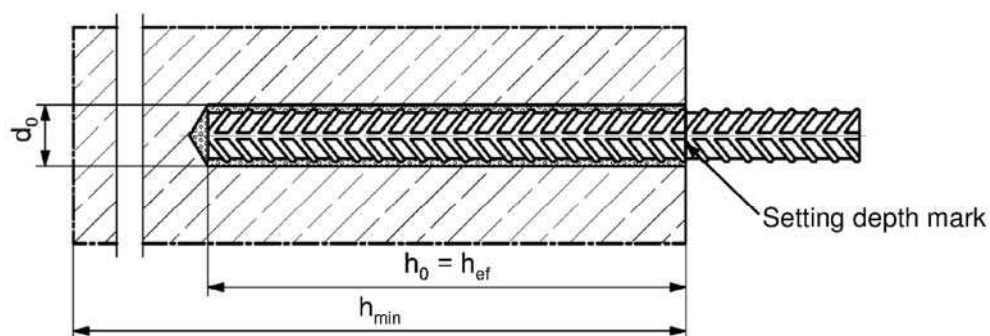

Figures not to scale

fischer Superbond

Intended use
Installation parameters reinforcing bars

Annex B 7

Table B8.1: Installation parameters for **fischer rebar anchor FRA**

Rebar anchor FRA		Thread	M12 ¹⁾	M16	M20	M24
Nominal diameter of the bar	ϕ	[mm]	12	16	20	25
Width across flats	SW		19	24	30	36
Nominal drill hole diameter	d_0		14	16	20	30
Drill hole depth	h_0		$h_{ef} + l_e$			
Effective embedment depth	$h_{ef,min}$		70	80	90	96
	$h_{ef,max}$		140	220	300	380
Distance concrete surface to welded joint	l_e		100			
Minimum spacing and minimum edge distance	s_{min} = c_{min}		55	65	85	105
Diameter of clearance hole in the fixture	pre-positioned anchorage $\leq d_f$		14	18	22	26
	push through anchorage $\leq d_f$		18	22	26	32
Minimum thickness of concrete member	h_{min}	$h_0 + 30$ (≥ 100)	$h_0 + 2d_0$			
Maximum torque moment for attachment of the fixture	$\max T_{fix}$	[Nm]	40	60	120	150

¹⁾ Both drill hole diameters can be used

fischer rebar anchor FRA

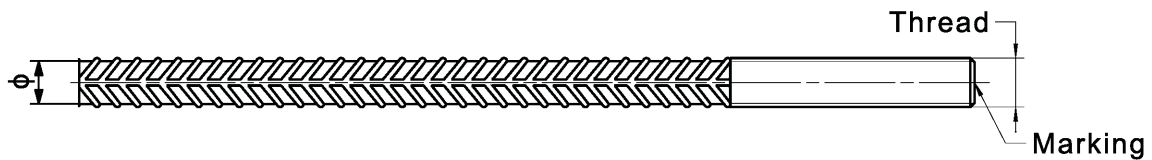

Marking frontal e. g:  FRA (for stainless steel);
 FRA C (for high corrosion resistant steel)

Installation conditions:

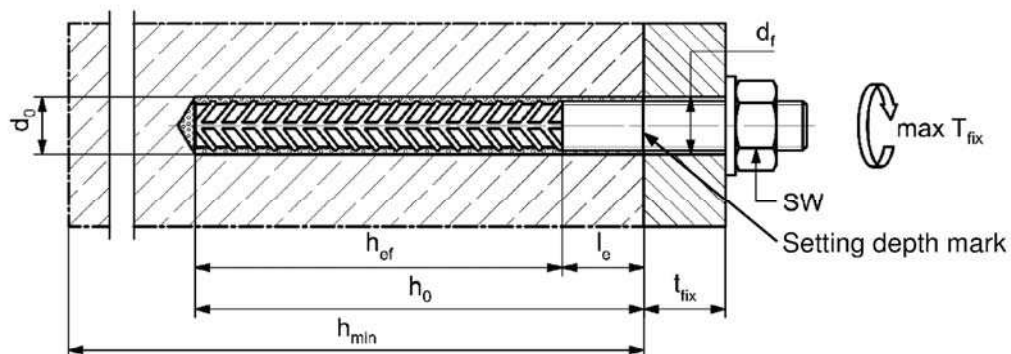

Figures not to scale

fischer Superbond

Intended use
Installation parameters rebar anchor FRA

Annex B 8

Table B9.1: Dimension of resin capsule RSB

Resin capsule RSB		RSB 8	RSB 10 mini	RSB 10	RSB 12 mini	RSB 12	RSB 16 mini	RSB 16	RSB 16 E	RSB 20	RSB 20 E / 24	RSB 30
Capsule diameter	d_P	9,0	10,5		12,5		16,5			23,0		27,5
Capsule length	L_P	85	72	90	72	97	72	95	123	160	190	260

**Table B9.2:** Assignment of resin capsule RSB to fischer anchor rod RG M

Anchor rod RG M		M8	M10	M12	M16	M20	M24	M30
Effective embedment depth	$h_{ef,1}$ [mm]	---	75	75	95	---	---	---
Related capsule RSB		---	10 mini	12 mini	16 mini	---	---	---
Effective embedment depth	$h_{ef,2}$ [mm]	80	90	110	125	170	210	280
Related capsule RSB		8	10	12	16	20	20 E / 24	30
Effective embedment depth	$h_{ef,3}$ [mm]	---	150	150	190	210	---	---
Related capsule RSB		---	2 x 10 mini	2 x 12 mini	2 x 16 mini	20 E / 24	---	---

Table B9.3: Assignment of resin capsule RSB to fischer internal threaded anchor RG MI

Internal threaded anchor RG MI		M8	M10	M12	M16	M20
Effective embedment depth	h_{ef} [mm]	90	90	125	160	200
Related capsule RSB		10	12	16	16 E	20 E / 24

Figures not to scale

fischer Superbond

Intended use

Dimensions of the capsules; Assignment of the capsule to the fischer anchor rod RG M and fischer internal threaded anchor RG MI

Annex B 9

Table B10.1: Parameters of the cleaning brush BS / BSB (steel brush)

The size of the cleaning brush refers to the drill hole diameter

Nominal drill hole diameter	d_0	[mm]	10	12	14	16	18	20	24	25	28	30	32	35	40
Steel brush diameter	d_b		11	14	16	20		25	26	27	30	40			42



Table B10.2: Maximum **processing time** of the mortar and minimum **curing time**
(During the curing time of the mortar the concrete temperature may not fall below the listed minimum temperature. Minimal cartridge temperature +5 °C; minimal resin capsule temperature -15 °C)

Temperature at anchoring base [°C]	Maximum processing time t_{work}		Minimum curing time t_{cure}		
	FIS SB	FIS SB High Speed	FIS SB	FIS SB High Speed	RSB
-30 to -20	---	---	---	---	120 h
> -20 to -15	---	60 min	---	24 h	48 h
> -15 to -10	60 min	30 min	36 h	8 h	30 h
> -10 to -5	30 min	15 min	24 h	3 h	16 h
> -5 to ±0	20 min	10 min	8 h	2 h	10 h
> ±0 to +5	13 min	5 min	4 h	1 h	45 min
> +5 to +10	9 min	3 min	2 h	45 min	30 min
> +10 to +20	5 min	2 min	1 h	30 min	20 min
> +20 to +30	4 min	1 min	45 min	15 min	5 min
> +30 to +40	2 min	---	30 min	---	3 min

Figures not to scale

fischer Superbond







Intended use

Cleaning brush (steel brush)
Processing time and curing time

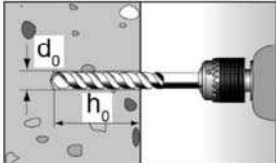
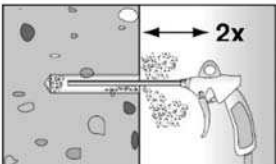
Annex B 10

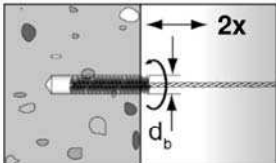
Installation instructions part 1; Injection mortar system FIS SB

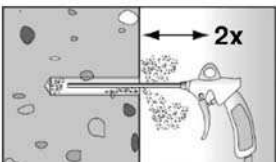
Drilling and cleaning the hole (hammer drilling with standard drill bit)

1		<p>Drill the hole. Nominal drill hole diameter d_0 and drill hole depth h_0 see tables B4.1, B6.1, B7.1, B8.1</p>	
2		<p>Clean the drill hole: Blow out the drill hole twice, with oil free compressed air ($p \geq 6$ bar) In uncracked concrete the use of the manual blow-out pump ABG is possible (Installation parameters: $d_0 < 18$ mm and $h_{ef} < 10d$)</p>	
3		<p>Brush the drill hole twice. For drill hole diameter ≥ 30 mm use a power drill. For deep holes use an extension. Corresponding brushes see table B10.1</p>	
4		<p>Clean the drill hole: Blow out the drill hole twice, with oil free compressed air ($p \geq 6$ bar) In uncracked concrete the use of the manual blow-out pump ABG is possible (Installation parameters: $d_0 < 18$ mm and $h_{ef} < 10d$)</p>	

Go to step 5 (Annex B 12)

Drilling and cleaning the hole (hammer drilling with hollow drill bit)

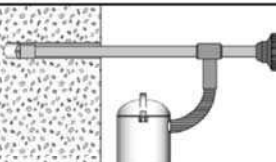
1		<p>Check a suitable hollow drill (see table B1.1) for correct operation of the dust extraction</p>
2		<p>Use a suitable dust extraction system, e. g. Bosch GAS 35 M AFC or a comparable dust extraction system with equivalent performance data. Drill the hole with hollow drill bit. The dust extraction system has to extract the drill dust nonstop during the drilling process and must be adjusted to maximum power. Nominal drill hole diameter d_0 and drill hole depth h_0 see tables B4.1, B6.1, B7.1, B8.1</p>

Go to step 5 (Annex B 12)

fischer Superbond



Intended use

Installation instructions part 1; injection mortar system FIS SB

Annex B 11

Installation instructions part 2; injection mortar system FIS SB

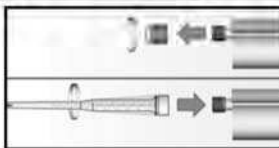
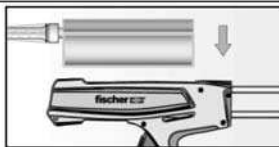
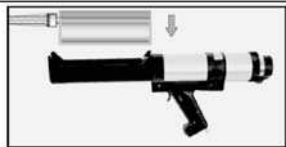
Preparing the cartridge

5		<p>Remove the sealing cap Screw on the static mixer (the spiral in the static mixer must be clearly visible)</p>
6		 <p>Place the cartridge into the dispenser</p>
7		 <p>Extrude approximately 10 cm of material out until the resin is evenly grey in colour. Do not use mortar that is not uniformly grey</p>

Injection of the mortar

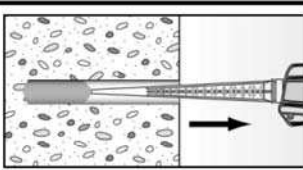
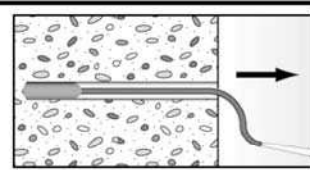
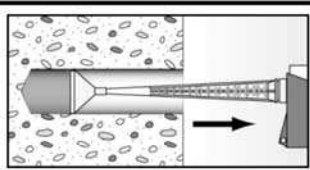
8	 <p>Fill approximately 2/3 of the drill hole with mortar. Always begin from the bottom of the hole and avoid bubbles</p>	 <p>For drill hole depth ≥ 150 mm use an extension tube</p>	 <p>For overhead installation, deep holes ($h_0 > 250$ mm) or drill hole diameter ($d_0 \geq 40$ mm) use an injection-adapter</p>
---	--	---	--

Go to step 9 (Annex B 13)





fischer Superbond

Intended use
Installation instructions part 2; injection mortar system FIS SB

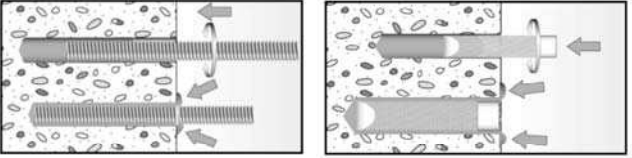

Annex B 12

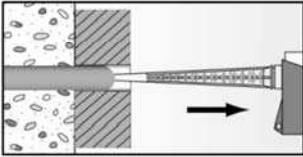
Installation instructions part 3; injection mortar system FIS SB

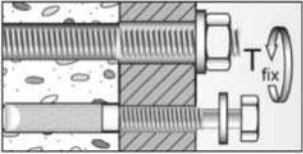
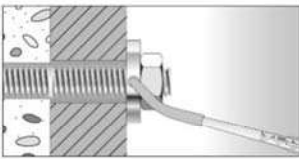
Installation of anchor rods or fischer internal threaded anchors RG MI

9		<p>Only use clean and oil-free anchor elements. Mark the setting depth of the anchor. Push the anchor rod or fischer internal threaded RG MI anchor down to the bottom of the hole, turning it slightly while doing so. After inserting the anchor element, excess mortar must be emerged around the anchor element. If not, pull out the anchor element immediately and reinject mortar.</p>
	 <p>For overhead installations support the anchor rod with wedges. (e. g. fischer centering wedges)</p>	 <p>For push through installation fill the annular gap with mortar</p>
11	 <p>Wait for the specified curing time t_{cure} see table B10.2</p>	 <p>12 Mounting the fixture max T_{fix} see tables B4.1 and B6.1</p>
Option		<p>After the minimum curing time is reached, the gap between anchor and fixture (annular clearance) may be filled with mortar via the fischer filling disc FFD. Compressive strength $\geq 50 \text{ N/mm}^2$ (e.g. fischer injection mortars FIS HB, FIS SB, FIS V, FIS EM Plus) ATTENTION: Using fischer filling disk FFD reduces t_{fix} (usable length of the anchor)</p>

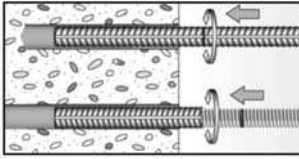
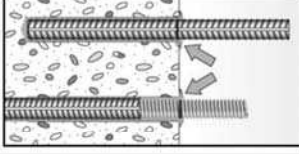
Installation reinforcing bars and fischer rebar anchor FRA

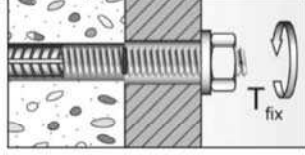
10		<p>Only use clean and oil-free reinforcing bars or fischer FRA. Mark the setting depth. Turn while using force to push the reinforcement bar or the fischer FRA into the filled hole up to the setting depth mark</p>
10		<p>When the setting depth mark is reached, excess mortar must be emerged from the mouth of the drill hole. If not, pull out the anchor element immediately and reinject mortar.</p>
11	 <p>Wait for the specified curing time t_{cure} see table B10.2</p>	 <p>12 Mounting the fixture max T_{fix} see table B8.1</p>

fischer Superbond	Annex B 13
<p>Intended use Installation instructions part 3; injection mortar system FIS SB</p>	

Installation instructions part 4; resin capsule RSB**Drilling and cleaning the hole (hammer drilling with standard drill bit)**

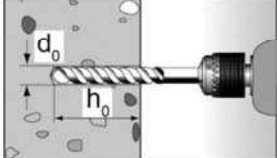
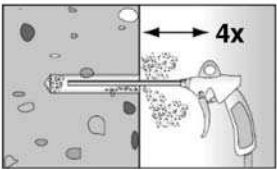
1		<p>Drill the hole. Nominal drill hole diameter d_0 and drill hole depth h_0 see tables B5.1 and B6.1</p>
2		<p>Clean the drill hole: Blow out the drill hole four times, with oil free compressed air ($p \geq 6$ bar) In uncracked concrete the use of the manual blow-out pump ABG is possible (Installation parameters: $d_0 < 18$ mm and $h_{ef} < 10d$)</p>



Go to step 6 (Annex B 15)

Drilling and cleaning the hole (wet drilling with diamond drill bit)

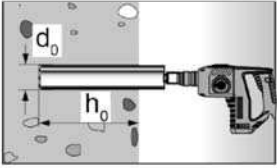
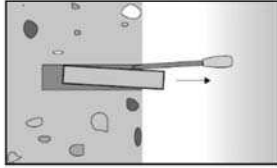
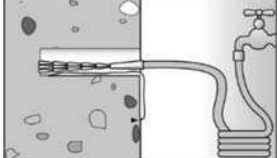
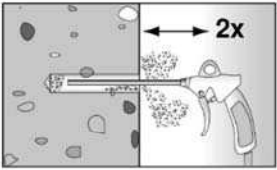
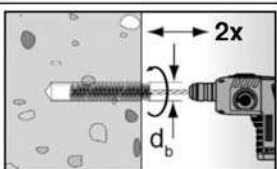
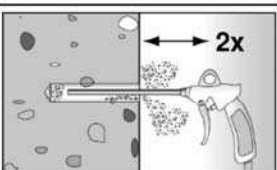
1		<p>Drill the hole. Drill hole diameter d_0 and drill hole depth h_0 see tables B5.1 and B6.1</p>	 <p>Break the drill core and remove it</p>
2		<p>Flush the drill hole with clean water until it flows clear</p>	
3		<p>Blow out the drill hole twice, using oil-free compressed air ($p > 6$ bar)</p>	
4		<p>Brush the drill hole twice using a power drill. Corresponding brushes see table B10.1</p>	
5		<p>Blow out the drill hole twice, using oil-free compressed air ($p > 6$ bar)</p>	

Go to step 6 (Annex B 15)

fischer Superbond

Intended use
Installation instructions part 4; resin capsule RSB

Annex B 14





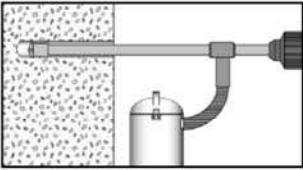

Installation instructions part 5; resin capsule RSB

Drilling and cleaning the hole (hammer drilling with hollow drill bit)

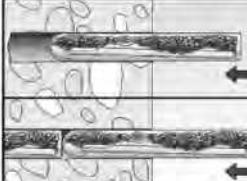
<p>1</p>		<p>Check a suitable hollow drill (see table B2.1) for correct operation of the dust extraction</p>
<p>2</p>		<p>Use a suitable dust extraction system, e. g. Bosch GAS 35 M AFC or a comparable dust extraction system with equivalent performance data.</p> <p>Drill the hole with hollow drill bit. The dust extraction system has to extract the drill dust nonstop during the drilling process and must be adjusted to maximum power. Nominal drill hole diameter d_0 and drill hole depth h_0 see tables B5.1 and B6.1</p>

Go to step 6 (Annex B 15)

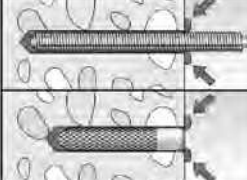
Installation fischer anchor rod RG M or fischer internal threaded anchor RG MI

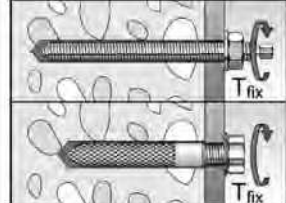
<p>6</p>		<p>Insert the resin capsule into the drill hole by hand. Suitable resin capsule RSB or RSB mini see table B9.2.</p>	 <p>Depending on the anchor being installed, use a suitable setting tool</p>
<p>7</p>			<p>Only use clean and grease-free anchors. Using a suitable adapter, drive the fischer anchor rod RG M or the fischer internal threaded anchor RG MI into the capsule using a hammer drill set on rotary hammer action. Stop when the anchor reaches the bottom of the hole and is set to the correct embedment depth</p>
<p>8</p>		<p>When reaching the correct embedment depth, excess mortar must emerge from the mouth of the drill hole. If not, the anchor must be pulled out directly and a second resin capsule must be pushed into the drill hole. Setting process must be repeated (Step 7)</p>	
<p>9</p>	 <p>Wait for the specified curing time, t_{cure} see table B10.2</p>	<p>10</p>	 <p>Mounting the fixture max T_{fix} see tables B5.1 and B6.1</p>

fischer Superbond

Intended use
Installation instructions part 5; resin capsule RSB

Annex B 15

Table C1.1: Essential characteristics ³⁾ for the steel bearing capacity under tensile / shear load of fischer anchor rods and standard threaded rods												
Anchor rod / standard threaded rod			M8	M10	M12	M16	M20	M24	M27	M30		
Bearing capacity under tensile load, steel failure												
Characteristic resistance $N_{Rk,s}$	Steel zinc plated	Property class	5.8	[kN]	19(17)	29(27)	43	79	123	177	230	281
			8.8		29(27)	47(43)	68	126	196	282	368	449
	Stainless steel A4 and high corrosion resistant steel C		50		19	29	43	79	123	177	230	281
			70		26	41	59	110	172	247	322	393
			80		30	47	68	126	196	282	368	449
Partial factors ¹⁾												
Partial factor $\gamma_{Ms,N}$	Steel zinc plated	Property class	5.8	[-]	1,50							
			8.8		1,50							
	Stainless steel A4 and high corrosion resistant steel C		50		2,86							
			70		1,50 ²⁾ / 1,87							
			80		1,60							
Bearing capacity under shear load, steel failure												
without lever arm												
Characteristic resistance $V_{Rk,s}^0$	Steel zinc plated	Property class	5.8	[kN]	9(8)	15(13)	21	39	61	89	115	141
			8.8		15(13)	23(21)	34	63	98	141	184	225
	Stainless steel A4 and high corrosion resistant steel C		50		9	15	21	39	61	89	115	141
			70		13	20	30	55	86	124	161	197
			80		15	23	34	63	98	141	184	225
Ductility factor		k_7	[-]	1,0								
with lever arm												
Characteristic resistance $M_{Rk,s}^0$	Steel zinc plated	Property class	5.8	[Nm]	19(16)	37(33)	65	166	324	560	833	1123
			8.8		30(26)	60(53)	105	266	519	896	1333	1797
	Stainless steel A4 and high corrosion resistant steel C		50		19	37	65	166	324	560	833	1123
			70		26	52	92	232	454	784	1167	1573
			80		30	60	105	266	519	896	1333	1797
Partial factors ¹⁾												
Partial factor $\gamma_{Ms,V}$	Steel zinc plated	Property class	5.8	[-]	1,25							
			8.8		1,25							
	Stainless steel A4 and high corrosion resistant steel C		50		2,38							
			70		1,25 ²⁾ / 1,56							
			80		1,33							
¹⁾ In absence of other national regulations ²⁾ Only admissible for high corrosion resistant steel C, with $f_{yk} / f_{uk} \geq 0,8$ and $A_5 > 12\%$ (e.g. fischer anchor rods) ³⁾ Values in brackets are valid for undersized threaded rods with smaller stress area A_s for hotdip galvanized standard threaded rods according to EN ISO 10684:2004+AC:2009												
fischer Superbond										Annex C 1		
Performance Essential characteristics for the steel bearing capacity of fischer anchor rods and standard threaded rods												

Table C2.1: Essential characteristics for the steel bearing capacity under tensile / shear load of fischer internal threaded anchors RG MI									
fischer internal threaded anchors RG MI			M8	M10	M12	M16	M20		
Bearing capacity under tensile load, steel failure									
Charact. resistance with screw	$N_{Rk,s}$	Property class	5.8	[kN]	19	29	43	79	123
			8.8		29	47	68	108	179
		Property class 70	A4		26	41	59	110	172
			C		26	41	59	110	172
Partial factors¹⁾									
Partial factors	$\gamma_{Ms,N}$	Property class	5.8	[-]	1,50				
			8.8		1,50				
		Property class 70	A4		1,87				
			C		1,87				
Bearing capacity under shear load, steel failure									
Without lever arm									
Charact. resistance with screw	$V^0_{Rk,s}$	Property class	5.8	[kN]	9,2	14,5	21,1	39,2	62,0
			8.8		14,6	23,2	33,7	54,0	90,0
		Property class 70	A4		12,8	20,3	29,5	54,8	86,0
			C		12,8	20,3	29,5	54,8	86,0
Ductility factor		k_7	[-]	1,0					
With lever arm									
Charact. resistance with screw	$M^0_{Rk,s}$	Property class	5.8	[Nm]	20	39	68	173	337
			8.8		30	60	105	266	519
		Property class 70	A4		26	52	92	232	454
			C		26	52	92	232	454
Partial factors¹⁾									
Partial factors	$\gamma_{Ms,V}$	Property class	5.8	[-]	1,25				
			8.8		1,25				
		Property class 70	A4		1,56				
			C		1,56				
¹⁾ In absence of other national regulations									
fischer Superbond								Annex C 2	
Performance Essential characteristics for the steel bearing capacity of fischer internal threaded anchor RG MI									

Table C3.1: Essential characteristics for the steel bearing capacity under tensile / shear load of reinforcing bars										
Nominal diameter of the bar	ϕ	8	10	12	14	16	20	25	28	32
Bearing capacity under tensile load, steel failure										
Characteristic resistance	$N_{Rk,s}$	[kN]	$A_s \cdot f_{uk}^{1)}$							
Bearing capacity under shear load, steel failure										
Without lever arm										
Characteristic resistance	$V^0_{Rk,s}$	[kN]	$0,5 \cdot A_s \cdot f_{uk}^{1)}$							
Ductility factor	k_7	[-]	0,8							
With lever arm										
Characteristic resistance	$M^0_{Rk,s}$	[Nm]	$1,2 \cdot W_{el} \cdot f_{uk}^{1)}$							
1) f_{uk} or f_{yk} respectively must be taken from the specifications of the reinforcing bar										
Table C3.2: Essential characteristics for the steel bearing capacity under tensile / shear load of fischer rebar anchors FRA										
fischer rebar anchor FRA			M12	M16	M20	M24				
Bearing capacity under tensile load, steel failure										
Characteristic resistance	$N_{Rk,s}$	[kN]	63	111	173	270				
Partial factor¹⁾										
Partial factor	$\gamma_{Ms,N}$	[-]	1,4							
Bearing capacity under shear load, steel failure										
Without lever arm										
Characteristic resistance	$V^0_{Rk,s}$	[kN]	30	55	86	124				
Ductility factor	k_7	[-]	1,0							
With lever arm										
Characteristic resistance	$M^0_{Rk,s}$	[Nm]	92	233	454	785				
Partial factor¹⁾										
Partial factor	$\gamma_{Ms,V}$	[-]	1,56							
1) In absence of other national regulations										
fischer Superbond							Annex C 3			
Performance Essential characteristics for the steel bearing capacity of reinforcing bars and fischer rebar anchors FRA										

Table C4.1: Essential characteristics under tensile / shear load											
Size		All sizes									
Tensile load											
Uncracked concrete	$k_{ucr,N}$	[-]	11,0								
Cracked concrete	$k_{cr,N}$		7,7								
Factors for the compressive strength of concrete > C20/25											
Increasing factor for τ_{RK}	C25/30	Ψ_c	[-]	1,02							
	C30/37			1,04							
	C35/45			1,07							
	C40/50			1,08							
	C45/55			1,09							
	C50/60			1,10							
Splitting failure											
Edge distance	$h / h_{ef} \geq 2,0$	$C_{cr,sp}$	[mm]	1,0 h_{ef}							
	$2,0 > h / h_{ef} > 1,3$			4,6 h_{ef} - 1,8 h							
	$h / h_{ef} \leq 1,3$			2,26 h_{ef}							
Spacing	$S_{cr,sp}$			2 $C_{cr,sp}$							
Concrete cone failure											
Edge distance	$C_{cr,N}$	[mm]	1,5 h_{ef}								
Spacing	$S_{cr,N}$		2 $C_{cr,N}$								
Factors for sustained tension load											
Temperature range		[-]	24 °C / 40 °C	50 °C / 80 °C	72 °C / 120 °C	90 °C / 150 °C					
Factor	Ψ_{sus}^0	[-]	0,84	0,86	0,84	0,91					
Shear load											
Installation factor	γ_{inst}	[-]	1,0								
Concrete pry-out failure											
Factor for pry-out failure	k_8	[-]	2,0								
Concrete edge failure											
value of h_{ef} (= l_f) under shear load		[-]	Conditions according to EN 1992-4:2018: chapter 7.2.2.5; Section 6; formular 7.43								
Calculation diameters											
Size			M8	M10	M12	M16	M20	M24	M27	M30	
fischer anchor rods and standard threaded rods	d_{nom}	[mm]	8	10	12	16	20	24	27	30	
fischer internal threaded anchors RG MI	d_{nom}		12	16	18	22	28	-	-	-	
fischer rebar anchor FRA	d_{nom}		-	-	12	16	20	25	-	-	
Size (nominal diameter of the bar)	ϕ		8	10	12	14	16	20	25	28	32
Reinforcing bar	d_{nom}	[mm]	8	10	12	14	16	20	25	28	32
fischer Superbond										Annex C 4	
Performance Essential characteristics under tensile / shear load											

Table C5.1: Essential characteristics of **tensile resistance** for **fischer anchor rods** and **standard threaded rods** in hammer drilled holes in combination with **injection mortar FIS SB; uncracked or cracked concrete**

Anchor rod / standard threaded rod		M8	M10	M12	M16	M20	M24	M27	M30	
Combined pullout and concrete cone failure										
Thread diameter	d	[mm]	8	10	12	16	20	24	27	30
Uncracked concrete										
Characteristic bond resistance in uncracked concrete C20/25										
<u>Hammer-drilling with standard drill bit or hollow drill bit (dry or wet concrete)</u>										
Temperature range	I: 24 °C / 40 °C	$\tau_{Rk,ucr}$ [N/mm ²]	12	13	13	13	13	12	10	10
	II: 50 °C / 80 °C		12	12	12	13	13	12	10	10
	III: 72 °C / 120 °C		10	11	11	11	11	11	9,0	9,0
	IV: 90 °C / 150 °C		10	10	10	11	10	10	8,0	8,0
Installation factors										
Dry or wet concrete	γ_{inst}	[-]	1,0							
Cracked concrete										
Characteristic bond resistance in cracked concrete C20/25										
<u>Hammer-drilling with standard drill bit or hollow drill bit (dry or wet concrete)</u>										
Temperature range	I: 24 °C / 40 °C	$\tau_{Rk,cr}$ [N/mm ²]	6,5	7,0	7,5	7,5	7,5	7,5	7,5	7,5
	II: 50 °C / 80 °C		6,0	6,5	7,5	7,5	7,5	7,5	7,0	7,0
	III: 72 °C / 120 °C		5,5	6,0	6,5	6,5	6,5	6,5	6,0	6,0
	IV: 90 °C / 150 °C		5,0	5,5	6,0	6,0	6,0	6,0	5,5	5,5
Installation factors										
Dry or wet concrete	γ_{inst}	[-]	1,0							
fischer Superbond										
Performance Essential characteristics of tensile resistance for fischer anchor rod and standard threaded rods with injection mortar FIS SB									Annex C 5	

Table C6.1: Essential characteristics of tensile resistance for fischer anchor rods RG M in hammer or diamond drilled holes in combination with resin capsule RSB; uncracked or cracked concrete									
Anchor rod RG M			M8	M10	M12	M16	M20	M24	M30
Combined pullout and concrete cone failure									
Thread diameter	d	[mm]	8	10	12	16	20	24	30
Uncracked concrete									
Characteristic bond resistance in uncracked concrete C20/25									
<u>Hammer-drilling with standard drill bit or hollow drill bit (dry or wet concrete as well as water filled hole)</u>									
Temperature range	I: 24 °C / 40 °C	$\tau_{Rk,ucr}$ [N/mm ²]	12	13	13	13	13	12	10
	II: 50 °C / 80 °C		12	12	12	13	13	12	10
	III: 72 °C / 120 °C		10	11	11	11	11	11	9,0
	IV: 90 °C / 150 °C		10	10	10	11	10	10	8,0
<u>Diamond-drilling (dry or wet concrete as well as water filled hole)</u>									
Temperature range	I: 24 °C / 40 °C	$\tau_{Rk,ucr}$ [N/mm ²]	13	13	14	14	14	13	11
	II: 50 °C / 80 °C		12	13	13	14	13	13	10
	III: 72 °C / 120 °C		11	12	12	12	12	11	9,5
	IV: 90 °C / 150 °C		10	11	11	11	11	10	8,5
Installation factors									
Dry or wet concrete	γ_{inst}	[-]	1,0						
Water filled hole		[-]	1,2	1,0					
Cracked concrete									
Characteristic bond resistance in cracked concrete C20/25									
<u>Hammer-drilling with standard drill bit or hollow drill bit (dry or wet concrete as well as water filled hole)</u>									
Temperature range	I: 24 °C / 40 °C	$\tau_{Rk,cr}$ [N/mm ²]	6,5	7,0	7,5	7,5	7,5	7,5	7,5
	II: 50 °C / 80 °C		6,0	6,5	7,5	7,5	7,5	7,5	7,0
	III: 72 °C / 120 °C		5,5	6,0	6,5	6,5	6,5	6,5	6,0
	IV: 90 °C / 150 °C		5,0	5,5	6,0	6,0	6,0	6,0	5,5
<u>Diamond-drilling (dry or wet concrete as well as water filled hole)</u>									
Temperature range	I: 24 °C / 40 °C	$\tau_{Rk,cr}$ [N/mm ²]	---	---	---	7,5	7,5	7,5	7,5
	II: 50 °C / 80 °C		---	---	---	7,5	7,5	7,5	7,0
	III: 72 °C / 120 °C		---	---	---	6,5	6,5	6,5	6,5
	IV: 90 °C / 150 °C		---	---	---	6,0	6,0	6,0	6,0
Installation factors									
Dry or wet concrete	γ_{inst}	[-]	1,0						
Water filled hole		[-]	1,2	1,0					
fischer Superbond									
Performance Essential characteristics of tensile resistance for fischer anchor rod RG M with resin capsule RSB								Annex C 6	

Table C7.1: Essential characteristics of tensile resistance for fischer internal threaded anchors RG MI in hammer drilled holes in combination with injection mortar FIS SB; uncracked or cracked concrete								
Internal threaded anchor RG MI			M8	M10	M12	M16	M20	
Combined pullout and concrete cone failure								
Sleeve diameter	d	[mm]	12	16	18	22	28	
Uncracked concrete								
Characteristic bond resistance in uncracked concrete C20/25								
Hammer-drilling with standard drill bit or hollow drill bit (dry or wet concrete)								
Temperature range	I: 24 °C / 40 °C	$\tau_{Rk,ucr}$ [N/mm ²]	12	12	11	11	9,5	
	II: 50 °C / 80 °C		12	11	11	10	9,0	
	III: 72 °C / 120 °C		11	10	10	9,0	8,0	
	IV: 90 °C / 150 °C		10	9,5	9,0	8,5	7,5	
Installation factors								
Dry or wet concrete	γ_{inst}	[-]					1,0	
Cracked concrete								
Characteristic bond resistance in cracked concrete C20/25								
Hammer-drilling with standard drill bit or hollow drill bit (dry or wet concrete)								
Temperature range	I: 24 °C / 40 °C	$\tau_{Rk,cr}$ [N/mm ²]					5,0	
	II: 50 °C / 80 °C						5,0	
	III: 72 °C / 120 °C						4,5	
	IV: 90 °C / 150 °C						4,0	
Installation factors								
Dry or wet concrete	γ_{inst}	[-]					1,0	
fischer Superbond							Annex C 7	
Performance Essential characteristics of tensile resistance for fischer internal threaded anchor RG MI with injection mortar FIS SB								

Table C8.1: Essential characteristics of tensile resistance for fischer internal threaded anchors RG MI in hammer or diamond drilled holes in combination with resin capsule RSB; uncracked or cracked concrete								
Internal threaded anchor RG MI			M8	M10	M12	M16	M20	
Combined pullout and concrete cone failure								
Sleeve diameter		d [mm]	12	16	18	22	28	
Uncracked concrete								
Characteristic bond resistance in uncracked concrete C20/25								
<u>Hammer-drilling with standard drill bit or hollow drill bit (dry or wet concrete as well as water filled hole)</u>								
Temperature range	I: 24 °C / 40 °C		$\tau_{Rk,ucr}$ [N/mm ²]	12	12	11	11	9,5
	II: 50 °C / 80 °C			12	11	11	10	9,0
	III: 72 °C / 120 °C			11	10	10	9,0	8,0
	IV: 90 °C / 150 °C			10	9,5	9,0	8,5	7,5
<u>Diamond-drilling (dry or wet concrete as well as water filled hole)</u>								
Temperature range	I: 24 °C / 40 °C		$\tau_{Rk,ucr}$ [N/mm ²]	13	12	12	11	10
	II: 50 °C / 80 °C			13	12	12	11	9,5
	III: 72 °C / 120 °C			11	11	10	9,5	8,5
	IV: 90 °C / 150 °C			10	10	9,5	9,0	8,0
Installation factors								
Dry or wet concrete		γ_{inst}	[-]	1,0				
Water filled hole		γ_{inst}	[-]	1,2	1,0			
Cracked concrete								
Characteristic bond resistance in cracked concrete C20/25								
<u>Hammer-drilling with standard drill bit or hollow drill bit (dry or wet concrete as well as water filled hole)</u>								
Temperature range	I: 24 °C / 40 °C		$\tau_{Rk,cr}$ [N/mm ²]	5,0				
	II: 50 °C / 80 °C			5,0				
	III: 72 °C / 120 °C			4,5				
	IV: 90 °C / 150 °C			4,0				
<u>Diamond-drilling (dry or wet concrete as well as water filled hole)</u>								
Temperature range	I: 24 °C / 40 °C		$\tau_{Rk,cr}$ [N/mm ²]	---	5,0			
	II: 50 °C / 80 °C			---	5,0			
	III: 72 °C / 120 °C			---	4,5			
	IV: 90 °C / 150 °C			---	4,0			
Installation factors								
Dry or wet concrete		γ_{inst}	[-]	1,0				
Water filled hole		γ_{inst}	[-]	1,2	1,0			
fischer Superbond							Annex C 8	
Performance Essential characteristics of tensile resistance for fischer internal threaded anchor RG MI with resin capsule RSB								

Table C9.1: Essential characteristics of tensile resistance for reinforcing bars in hammer drilled holes in combination with injection mortar FIS SB; uncracked or cracked concrete													
Nominal diameter of the bar		ϕ	8	10	12	14	16	20	25	28	32		
Combined pullout and concrete cone failure													
Bar diameter		d	[mm]	8	10	12	14	16	20	25	28	32	
Uncracked concrete													
Characteristic bond resistance in uncracked concrete C20/25													
Hammer-drilling with standard drill bit or hollow drill bit (dry or wet concrete)													
Tem- perature range	I: 24 °C / 40 °C		$\tau_{Rk,ucr}$	[N/mm ²]	8,0	8,5	9,0	9,5	9,5	10	9,5	9,0	7,5
	II: 50 °C / 80 °C				8,0	8,5	9,0	9,0	9,5	9,5	9,0	8,5	7,5
	III: 72 °C / 120 °C				7,0	7,5	8,0	8,0	8,5	8,5	8,0	7,5	6,5
	IV: 90 °C / 150 °C				6,5	7,0	7,0	7,5	7,5	8,0	7,5	7,0	6,0
Installation factors													
Dry or wet concrete		γ_{inst}	[-]	1,0									
Cracked concrete													
Characteristic bond resistance in cracked concrete C20/25													
Hammer-drilling with standard drill bit or hollow drill bit (dry or wet concrete)													
Tem- perature range	I: 24 °C / 40 °C		$\tau_{Rk,cr}$	[N/mm ²]	4,5	6,0	6,0	6,0	7,0	6,0	6,0	6,0	6,0
	II: 50 °C / 80 °C				4,5	5,5	5,5	5,5	6,5	6,0	6,0	6,0	6,0
	III: 72 °C / 120 °C				4,0	5,0	5,0	5,0	6,0	5,5	5,5	5,5	5,5
	IV: 90 °C / 150 °C				3,5	4,5	4,5	4,5	5,5	5,0	5,0	5,0	5,0
Installation factors													
Dry or wet concrete		γ_{inst}	[-]	1,0									
fischer Superbond											Annex C 9		
Performance Essential characteristics of tensile resistance for reinforcing bars with injection mortar FIS SB													

Table C10.1: Essential characteristics of tensile resistance for fischer rebar anchors FRA in hammer drilled holes in combination with injection mortar FIS SB; uncracked or cracked concrete						
fischer rebar anchor FRA		M12	M16	M20	M24	
Combined pullout and concrete cone failure						
Bar diameter	d	[mm]	12	16	20	25
Uncracked concrete						
Characteristic bond resistance in uncracked concrete C20/25						
Hammer-drilling with standard drill bit or hollow drill bit (dry or wet concrete)						
Temperature range	I: 24 °C / 40 °C	$\tau_{Rk,ucr}$ [N/mm ²]	9,0	9,5	10	9,5
	II: 50 °C / 80 °C		9,0	9,5	9,5	9,0
	III: 72 °C / 120 °C		8,0	8,5	8,5	8,0
	IV: 90 °C / 150 °C		7,0	7,5	8,0	7,5
Installation factors						
Dry or wet concrete	γ_{inst}	[-]	1,0			
Cracked concrete						
Characteristic bond resistance in cracked concrete C20/25						
Hammer-drilling with standard drill bit or hollow drill bit (dry or wet concrete)						
Temperature range	I: 24 °C / 40 °C	$\tau_{Rk,cr}$ [N/mm ²]	6,0	7,0	6,0	6,0
	II: 50 °C / 80 °C		5,5	6,5	6,0	6,0
	III: 72 °C / 120 °C		5,0	6,0	5,5	5,5
	IV: 90 °C / 150 °C		4,5	5,5	5,0	5,0
Installation factors						
Dry or wet concrete	γ_{inst}	[-]	1,0			
fischer Superbond					Annex C 10	
Performance Essential characteristics of tensile resistance for fischer rebar anchors FRA with injection mortar FIS SB						

Table C11.1: Displacements for anchor rods									
Anchor rod		M8	M10	M12	M16	M20	M24	M27	M30
Displacement-Factors for tensile load¹⁾									
Uncracked or cracked concrete; Temperature range I, II, III, IV									
δ_{N0} -Factor	[mm/(N/mm ²)]	0,07	0,08	0,09	0,10	0,11	0,12	0,12	0,13
$\delta_{N\infty}$ -Factor		0,13	0,14	0,15	0,17	0,17	0,18	0,19	0,19
Displacement-Factors for shear load²⁾									
Uncracked or cracked concrete; Temperature range I, II, III, IV									
δ_{V0} -Factor	[mm/kN]	0,18	0,15	0,12	0,09	0,07	0,06	0,05	0,05
$\delta_{V\infty}$ -Factor		0,27	0,22	0,18	0,14	0,11	0,09	0,08	0,07
1) Calculation of effective displacement: $\delta_{N0} = \delta_{N0}\text{-Factor} \cdot \tau_{Ed}$ $\delta_{N\infty} = \delta_{N\infty}\text{-Factor} \cdot \tau_{Ed}$ (τ_{Ed} : Design value of the applied tensile stress)					2) Calculation of effective displacement: $\delta_{V0} = \delta_{V0}\text{-Factor} \cdot V_{Ed}$ $\delta_{V\infty} = \delta_{V\infty}\text{-Factor} \cdot V_{Ed}$ (V_{Ed} : Design value of the applied shear force)				
Table C11.2: Displacements for fischer internal threaded anchors RG MI									
Internal threaded anchor RG MI		M8	M10	M12	M16	M20			
Displacement-Factors for tensile load¹⁾									
Uncracked or cracked concrete; Temperature range I, II, III, IV									
δ_{N0} -Factor	[mm/(N/mm ²)]	0,09	0,10	0,10	0,11	0,19			
$\delta_{N\infty}$ -Factor		0,13	0,15	0,15	0,17	0,19			
Displacement-Factors for shear load²⁾									
Uncracked or cracked concrete; Temperature range I, II, III, IV									
δ_{V0} -Factor	[mm/kN]	0,12	0,09	0,08	0,07	0,05			
$\delta_{V\infty}$ -Factor		0,18	0,14	0,12	0,10	0,08			
1) Calculation of effective displacement: $\delta_{N0} = \delta_{N0}\text{-Factor} \cdot \tau_{Ed}$ $\delta_{N\infty} = \delta_{N\infty}\text{-Factor} \cdot \tau_{Ed}$ (τ_{Ed} : Design value of the applied tensile stress)					2) Calculation of effective displacement: $\delta_{V0} = \delta_{V0}\text{-Factor} \cdot V_{Ed}$ $\delta_{V\infty} = \delta_{V\infty}\text{-Factor} \cdot V_{Ed}$ (V_{Ed} : Design value of the applied shear force)				
fischer Superbond							Annex C 11		
Performance Displacements for anchor rods and fischer internal threaded anchors RG MI									

Table C12.1: Displacements for reinforcing bars										
Nominal diameter of the bar ϕ		8	10	12	14	16	20	25	28	32
Displacement-Factors for tensile load¹⁾										
Uncracked or cracked concrete; Temperature range I, II, III, IV										
δ_{N0} -Factor	[mm/(N/mm ²)]	0,07	0,08	0,09	0,09	0,10	0,11	0,12	0,13	0,13
$\delta_{N\infty}$ -Factor		0,11	0,13	0,13	0,15	0,16	0,16	0,18	0,20	0,20
Displacement-Factors for shear load²⁾										
Uncracked or cracked concrete; Temperature range I, II, III, IV										
δ_{V0} -Factor	[mm/kN]	0,18	0,15	0,12	0,10	0,09	0,07	0,06	0,05	0,05
$\delta_{V\infty}$ -Factor		0,27	0,22	0,18	0,16	0,14	0,11	0,09	0,08	0,06
1) Calculation of effective displacement: $\delta_{N0} = \delta_{N0}\text{-Factor} \cdot \tau_{Ed}$ $\delta_{N\infty} = \delta_{N\infty}\text{-Factor} \cdot \tau_{Ed}$ (τ_{Ed} : Design value of the applied tensile stress)					2) Calculation of effective displacement: $\delta_{V0} = \delta_{V0}\text{-Factor} \cdot V_{Ed}$ $\delta_{V\infty} = \delta_{V\infty}\text{-Factor} \cdot V_{Ed}$ (V_{Ed} : Design value of the applied shear force)					
Table C12.2: Displacements for fischer rebar anchors FRA										
fischer rebar anchor FRA		M12	M16	M20	M24					
Displacement-Factors for tensile load¹⁾										
Uncracked or cracked concrete; Temperature range I, II, III, IV										
δ_{N0} -Factor	[mm/(N/mm ²)]	0,09	0,10	0,11	0,12					
$\delta_{N\infty}$ -Factor		0,13	0,15	0,16	0,18					
Displacement-Factors for shear load²⁾										
Uncracked or cracked concrete; Temperature range I, II, III, IV										
δ_{V0} -Factor	[mm/kN]	0,12	0,09	0,07	0,06					
$\delta_{V\infty}$ -Factor		0,18	0,14	0,11	0,09					
1) Calculation of effective displacement: $\delta_{N0} = \delta_{N0}\text{-Factor} \cdot \tau_{Ed}$ $\delta_{N\infty} = \delta_{N\infty}\text{-Factor} \cdot \tau_{Ed}$ (τ_{Ed} : Design value of the applied tensile stress)					2) Calculation of effective displacement: $\delta_{V0} = \delta_{V0}\text{-Factor} \cdot V_{Ed}$ $\delta_{V\infty} = \delta_{V\infty}\text{-Factor} \cdot V_{Ed}$ (V_{Ed} : Design value of the applied shear force)					
fischer Superbond									Annex C 12	
Performance Displacements for reinforcing bars and fischer rebar anchors FRA										

Table C13.1: Essential characteristics ²⁾ for the steel bearing capacity under tensile / shear load of fischer anchor rods and standard threaded rods under seismic action performance category C1 or C2											
Anchor rod / standard threaded rod			M8	M10	M12	M16	M20	M24	M27	M30	
Bearing capacity under tensile load, steel failure¹⁾											
fischer anchor rods and standard threaded rods, performance category C1											
Characteristic resistance $N_{Rk,s,eq,C1}$	Steel zinc plated	Property class	5.8	19	29(27)	43	79	123	177	230	281
			8.8	30	47(43)	68	126	196	282	368	449
	Stainless steel A4 and high corrosion resistant steel C		50	19	29	43	79	123	177	230	281
			70	26	41	59	110	172	247	322	393
			80	30	47	68	126	196	282	368	449
fischer anchor rods and standard threaded rods, performance category C2											
Characteristic resistance $N_{Rk,s,eq,C2}$	Steel zinc plated	Property class	5.8	---	---	39	72	108	177	---	---
			8.8	---	---	61	116	173	282	---	---
	Stainless steel A4 and high corrosion resistant steel C		50	---	---	39	72	108	177	---	---
			70	---	---	53	101	152	247	---	---
			80	---	---	61	116	173	282	---	---
Bearing capacity under shear load, steel failure without lever arm¹⁾											
fischer anchor rods, performance category C1											
Characteristic resistance $V_{Rk,s,eq,C1}^0$	Steel zinc plated	Property class	5.8	9	15(13)	21	39	61	89	115	141
			8.8	15	23(21)	34	63	98	141	184	225
	Stainless steel A4 and high corrosion resistant steel C		50	9	15	21	39	61	89	115	141
			70	13	20	30	55	86	124	161	197
			80	15	23	34	63	98	141	184	225
Standard threaded rods, performance category C1											
Characteristic resistance $V_{Rk,s,eq,C1}^0$	Steel zinc plated	Property class	5.8	6	11(9)	15	27	43	62	81	99
			8.8	11	16(14)	24	44	69	99	129	158
	Stainless steel A4 and high corrosion resistant steel C		50	6	11	15	27	43	62	81	99
			70	9	14	21	39	60	87	113	138
			80	11	16	24	44	69	99	129	158
fischer anchor rods and standard threaded rods, performance category C2											
Characteristic resistance $V_{Rk,s,eq,C2}^0$	Steel zinc plated	Property class	5.8	---	---	14	27	43	62	---	---
			8.8	---	---	22	44	69	99	---	---
	Stainless steel A4 and high corrosion resistant steel C		50	---	---	14	27	43	62	---	---
			70	---	---	20	39	60	87	---	---
			80	---	---	22	44	69	99	---	---
<p>1) Partial factors for performance category C1 or C2 see table C14.2; for fischer anchor rods FIS A / RG M the factor for steel ductility is 1,0</p> <p>2) Values in brackets are valid for undersized threaded rods with smaller stress area A_s for hotdip galvanized standard threaded rods according to EN ISO 10684:2004+AC:2009.</p>											
fischer Superbond										Annex C 13	
Performance Essential characteristics for the steel bearing capacity for fischer anchor rods and standard threaded rods under seismic action (performance category C1 / C2)											

Table C14.1: Essential characteristics for the **steel bearing capacity** under tensile / shear load of **reinforcing bars (B500B)** under seismic action performance category **C1**

Nominal diameter of the bar	ϕ	8	10	12	14	16	20	25	28	32
Bearing capacity under tensile load, steel failure¹⁾										
Reinforcing bar B500B acc. to DIN 488-2:2009-08, performance category C1										
Characteristic resistance	$N_{Rk,s,eq,C1}$ [kN]	28	44	63	85	111	173	270	339	443
Bearing capacity under shear load, steel failure without lever arm¹⁾										
Reinforcing bar B500B acc. to DIN 488-2:2009-08, performance category C1										
Characteristic resistance	$V^0_{Rk,s,eq,C1}$ [kN]	10	15	22	30	39	61	95	119	155

¹⁾ Partial factors for performance category C1 see table C14.2

Table C14.2: **Partial factors** for **fischer anchor rods, standard threaded rods** and **reinforcing bars (B500B)** under seismic action performance category **C1 or C2**

Anchor rod / standard threaded rod		M8	M10	M12	M16	M20	M24	M27	M30	
Nominal diameter of the bar	ϕ	8	10	12	14	16	20	25	28	32
Tensile load, steel failure¹⁾										
Partial factor $\gamma_{Ms,N}$	Steel zinc plated	5.8	[-]	1,50						
		8.8		1,50						
	Stainless steel A4 and high corrosion resistant steel C	50		2,86						
		70		1,50 ²⁾ / 1,87						
		80		1,60						
	Reinforcing bar	B500B		1,40						
Shear load, steel failure¹⁾										
Partial factor $\gamma_{Ms,V}$	Steel zinc plated	5.8	[-]	1,25						
		8.8		1,25						
	Stainless steel A4 and high corrosion resistant steel C	50		2,38						
		70		1,25 ²⁾ / 1,56						
		80		1,33						
	Reinforcing bar	B500B		1,50						

¹⁾ In absence of other national regulations

²⁾ Only admissible for high corrosion resistant steel C, with $f_{yk} / f_{uk} \geq 0,8$ and $A_5 > 12\%$ (e.g. fischer anchor rods)

fischer Superbond

Performance

Essential characteristics for the steel bearing capacity for reinforcing bars under seismic action (performance category C1); partial factors (performance category C1 / C2)

Annex C 14

Table C15.1: Essential characteristics of **resistance** for **fischer anchor rods** and **standard threaded rods** in hammer drilled holes with **injection mortar FIS SB** or **resin capsule RSB** under seismic action performance category **C1**

Anchor rod / standard threaded rod		M8	M10	M12	M16	M20	M24	M27 ¹⁾	M30	
Characteristic bond resistance, combined pullout and concrete cone failure										
Hammer-drilling with standard drill bit or hollow drill bit (dry or wet concrete; resin capsule RSB additional in water filled holes)										
Tem- perature range	I: 24 °C / 40 °C	$\tau_{RK,eq,C1}$ [N/mm ²]	4,6	5,0	5,6	5,6	5,6	5,6	5,6	6,4
	II: 50 °C / 80 °C		4,3	4,6	5,6	5,6	5,6	5,6	5,3	6,0
	III: 72 °C / 120 °C		3,9	4,3	4,9	4,9	4,9	4,9	4,5	5,1
	IV: 90 °C / 150 °C		3,6	3,9	4,5	4,5	4,5	4,5	4,1	4,7

Installation factors

Tensile load

Dry or wet concrete	γ_{inst}	[-]	1,0						
Water filled hole	γ_{inst}	[-]	1,2 ²⁾	1,0 ²⁾					

Shear load

All installation conditions	γ_{inst}	[-]	1,0						
-----------------------------	-----------------	-----	-----	--	--	--	--	--	--

¹⁾ Only use with injection mortar FIS SB

²⁾ Only use with resin capsule RSB in water filled hole

Table C15.2: Essential characteristics of **resistance** for **reinforcing bars** in hammer drilled holes with **injection mortar FIS SB** under seismic action performance category **C1**

Nominal diameter of the bar		ϕ	8	10	12	14	16	20	25	28	32
Characteristic bond resistance, combined pullout and concrete cone failure											
Hammer-drilling with standard drill bit or hollow drill bit (dry or wet concrete)											
Tem- perature range	I: 24 °C / 40 °C	$\tau_{RK,eq,C1}$ [N/mm ²]	3,2	4,3	4,5	4,5	5,3	4,5	4,5	4,5	5,1
	II: 50 °C / 80 °C		3,2	3,9	4,1	4,1	4,9	4,5	4,5	4,5	5,1
	III: 72 °C / 120 °C		2,8	3,6	3,8	3,8	4,5	4,1	4,1	4,1	4,7
	IV: 90 °C / 150 °C		2,5	3,2	3,4	3,4	4,1	3,8	3,8	3,8	4,3

Installation factors

Tensile load

Dry or wet concrete	γ_{inst}	[-]	1,0								
---------------------	-----------------	-----	-----	--	--	--	--	--	--	--	--

Shear load

All installation conditions	γ_{inst}	[-]	1,0								
-----------------------------	-----------------	-----	-----	--	--	--	--	--	--	--	--

fischer Superbond

Performance

Essential characteristics under seismic action (performance category C1) for fischer anchor rods, standard threaded rods and reinforcing bars

Annex C 15

Table C16.1: Essential characteristics of **resistance** for **fischer anchor rods** and **standard threaded rods** in hammer drilled holes with **injection mortar FIS SB** under seismic action performance category **C2**

Anchor rod / standard threaded rod		M12	M16	M20	M24	
Characteristic bond resistance, combined pullout and concrete cone failure						
Hammer-drilling with standard drill bit or hollow drill bit (dry or wet concrete)						
Temperature range	I: 24 °C / 40 °C	$\tau_{RK,eq,C2}$ [N/mm ²]	4,5	3,2	2,6	3,0
	II: 50 °C / 80 °C		4,5	3,2	2,6	3,0
	III: 72 °C / 120 °C		3,9	2,7	2,3	2,6
	IV: 90 °C / 150 °C		3,6	2,5	2,1	2,4
Installation factors						
Tensile load						
Dry or wet concrete	γ_{inst}	[-]	1,0			
Shear load						
All installation conditions	γ_{inst}	[-]	1,0			
Displacement-Factors for tensile load¹⁾						
$\delta_{N,(DLS)}$ -Factor	[mm/(N/mm ²)]	0,09	0,10	0,11	0,12	
$\delta_{N,(ULS)}$ -Factor		0,15	0,17	0,17	0,18	
Displacement-Factors for shear load²⁾						
$\delta_{V,(DLS)}$ -Factor	[mm/kN]	0,18	0,10	0,07	0,06	
$\delta_{V,(ULS)}$ -Factor		0,25	0,14	0,11	0,09	
¹⁾ Calculation of effective displacement: $\delta_{N,(DLS)} = \delta_{N,(DLS)-Factor} \cdot \tau_{Ed}$ $\delta_{N,(ULS)} = \delta_{N,(ULS)-Factor} \cdot \tau_{Ed}$ (τ_{Ed} : Design value of the applied tensile stress)			²⁾ Calculation of effective displacement: $\delta_{V,(DLS)} = \delta_{V,(DLS)-Factor} \cdot V_{Ed}$ $\delta_{V,(ULS)} = \delta_{V,(ULS)-Factor} \cdot V_{Ed}$ (V_{Ed} : Design value of the applied shear force)			
fischer Superbond					Annex C 16	
Performance Essential characteristics under seismic action (performance category C2) for fischer anchor rods and standard threaded rods						